



## Data sheet

### VME-VD80-15016

VME board level product

Your partner in automation

## Galvanic isolated 16 channel transient recorder

### Features

- 16 channels
- Simultaneous sampling
- 100 kHz bandwidth
- Max. 200 kS/s per channel
- Direct readout and/or transient recorder function
- Input range +/- 10 Volt
- 16 bit resolution
- Differential input
- Common mode range +/- 270 Volt, each channel
- Input protection +/- 500 Volt, each channel
- Galvanic isolation
- 32 MB of onboard memory per channel
- Samples also available via FIFO's
- Selectable trigger options
- 32 bit time stamp counter
- Programmable digital filtering (optional)
- Pre and post trigger recording
- 6U high, single slot VME64 form factor

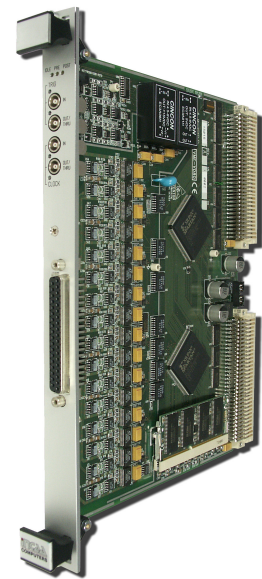

### Description

This module is a 16 channel digitizer with onboard memory, in a 6U high VME64 form factor. The analog input section is galvanic isolated from the VME bus. All channels are sampled simultaneous with 16 bit resolution and samples are stored in onboard memory. The memory is organized as a ring buffer. On every sample clock the A to D converters convert the analog inputs simultaneous and send the samples over the isolation barrier where they are stored into the ring buffer. After the event of a trigger a programmable number of post trigger samples will be stored into this ring buffer before sampling stops. The samples in memory can be read with DMA transfers.

In parallel samples are also available to VME through FIFO or Ring buffers at sub sample rates for control applications. The depth of these buffers is software selectable; up to 512 samples per channel.

Modules may be connected via the front panel trigger and clock signals to increase the number of channels.

The plug and play functionality provides easy setup and use.

***Design and manufacturing of computer systems for industry, science and OEM***



## Data sheet

### VME-VD80-15016

VME board level product

Your partner in automation

## Sampling process

### Record

The recording process consists of three states. The **IDLE** state is used to configure the module and read the sampled data from the memory after a shot has been recorded. The sampling process starts when the module is placed in the **PRE-TRIG** state using the **START** command. All 16 channels will record their sampled values in memory. When a trigger has been received or a **TRIG** command is given, the module enters the **POST-TRIG** state and remains there until the specified number of post-trigger samples has been recorded or the sampling process is stopped. Stopping is always possible using the **STOP** command.

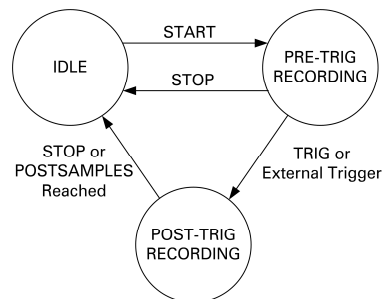

The sampled data is recorded in 16 different memory segments, one for each channel, during **PRE-TRIG** and **POST-TRIG** states. When a trigger is received the number of post-trigger samples is counted. The total number of recorded samples, is also counted.

### Direct readout

At a specified sub-sample rate the samples can also be stored in Sub-sample buffers. This process can start when the **SUBSTART** command has been given or after a **SUBSTART** command plus a trigger (when the trigger functionality has been enabled). **SUBSTOP** will stop the storage of the sub-samples in the buffer.

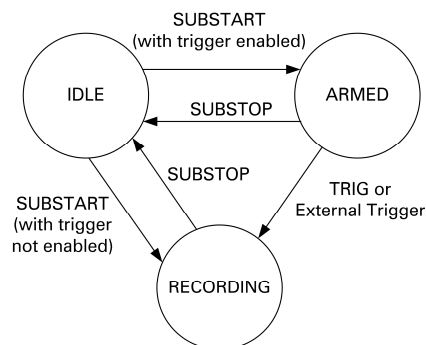

The Sub-sample buffers can be used in a FIFO or ring-buffer mode, both with depth of up to 512 samples. This is all software selectable. The advantage of the FIFO mode is that after the FIFO has been filled no further samples are recorded. The advantage of the ring-buffer mode is that new data is always recorded and oldest data is overwritten.

**Design and manufacturing of computer systems for industry, science and OEM**



## Data sheet

### VME-VD80-15016

VME board level product

Your partner in automation

## Technical Specifications

### INPUT

- Number of inputs : 16
- Input type : differential
- Input range : +/- 10 Volt, other ranges on request
- Full power bandwidth : 100 kHz
- Small signal bandwidth : 100 kHz
- Full scale step response overshoot : < 10 %
- Differential input impedance : typ. 800 kOhm
- Common mode rejection : > 90 dB @ DC to 500 Hz  
83 dB @ 1 kHz  
64 dB @ 10 kHz  
47 dB @ 100 kHz
- Common mode rejection over the isolation barrier : > 90 dB @ DC to 1 kHz  
82 dB @ 10 kHz  
64 dB @ 100 kHz
- Common mode range : +/- 270 Volt
- Damage limit : +/- 500 Volt differential or common mode
- Input connector : 37 pole D-connector, female.  
JET standard pin out YA-A009-0436

### TRANSFER CHARACTERISTICS

- Sample rate : max 200 kS/s per channel
- Resolution : 16 bits
- No missing codes : typ. 16 bits, min. 15 bits
- INL : typ. +/- 1 LSB max. +/- 3 LSB
- DNL : typ. 0.5 LSB, min. -2 LSB, max. +3 LSB
- SNR : > 80 dB @ 10 kHz full scale
- THD : < -70 dB @ 10 kHz full scale
- Gain error : < 0.05 % of full scale range over operating temperature range
- Offset error : ≤ 3 LSB over operating temperature range
- Cross talk between channels : < -80 dB

### MEMORY

- Main memory record length : 32 MB (16 MS) per channel
- Main memory configuration : 16 ring buffers, one for each channel
- Sub-sample memory record length : max. 512 samples per channel
- Sub-sample memory configuration : 16 ring buffers or FIFO's, one for each channel

*Design and manufacturing of computer systems for industry, science and OEM*



## **Data sheet**

### **VME-VD80-15016**

**VME board level product**

**Your partner in automation**

#### **VME INTERFACE**

- Board type : Slave
- Interface : A16/A32 D32/D16/D8(E)/D8(O)
- Block transfers : Yes

#### **SAMPLE CLOCK**

- Source : internal or external
- Sample rate internal clock : 200 kS/s divided by 1 to 65535, programmable
- Internal sample clock stability : 50 ppm over operating temperature range.
- External sample clock input : TTL, 50 Ohm termination selectable, edge selectable
- External sample clock output : TTL, short circuit protected, 50 Ohm driving capability
- External clock input pulse width (min) : 50 ns
- External sample clock connectors : 2 x LEMO 00

#### **TRIGGER**

- Source : internal or external
- Trigger input : TTL, 50 Ohm termination selectable, edge selectable
- Trigger output : TTL, short circuit protected, 50 Ohm driving capability
- Trigger connectors : 2 x LEMO 00

#### **ISOLATION**

- Isolation barrier : > 200 V working voltage (RMS or DC).  
: > 1500V RMS 50/60 Hz, 1 min.
- Signal transfer : inductive couplers
- Power transfer : DC/DC converters, no external power required

#### **MECHANICAL**

- Height : 6U
- Width : 1 slot

#### **ENVIRONMENTAL CONDITIONS**

- Max. operating relative humidity : 90 %, no condensation
- Operating temperature : 15 – 40 °C
- Power supply requirements : + 5 Volt derived from VME, 2.3 A typ.

#### **WARRANTY**

: 1 year

#### **ORDERING INFORMATION**

- VME-VD80-15016 : 29-15016-6

***Design and manufacturing of computer systems for industry, science and OEM***



## Data sheet

### VME-VD80-15016

VME board level product

Your partner in automation

### Analog input connector

A 37 pin Sub-D female connector is available to connect the 16 analog input signals. The pin assignment is as follows:

Pin	Signal
1	Channel 1 +
2	Channel 2 +
3	Channel 3 +
4	Channel 4 +
5	Channel 5 +
6	Channel 6 +
7	Channel 7 +
8	Channel 8 +
9	Channel 9 +
10	Channel 10 +
11	Channel 11 +
12	Channel 12 +
13	Channel 13 +
14	Channel 14 +
15	Channel 15 +
16	Channel 16 +
17	Not connected
18	Not connected
19	Isolated ground

Pin	Signal
20	Channel 1 -
21	Channel 2 -
22	Channel 3 -
23	Channel 4 -
24	Channel 5 -
25	Channel 6 -
26	Channel 7 -
27	Channel 8 -
28	Channel 9 -
29	Channel 10 -
30	Channel 11 -
31	Channel 12 -
32	Channel 13 -
33	Channel 14 -
34	Channel 15 -
35	Channel 16 -
36	Not connected
37	Isolated ground

For the best signal quality the isolated ground (pin 19 and 37) must be connected to the ground of the system where the signals originate.

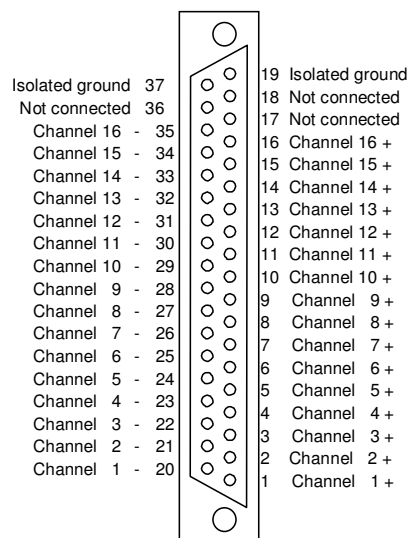

Front view of frontpanel female sub -D connector

**Design and manufacturing of computer systems for industry, science and OEM**



**Data sheet**

**VME-VD80-15016**

VME board level product

Your partner in automation

**Block Diagram**

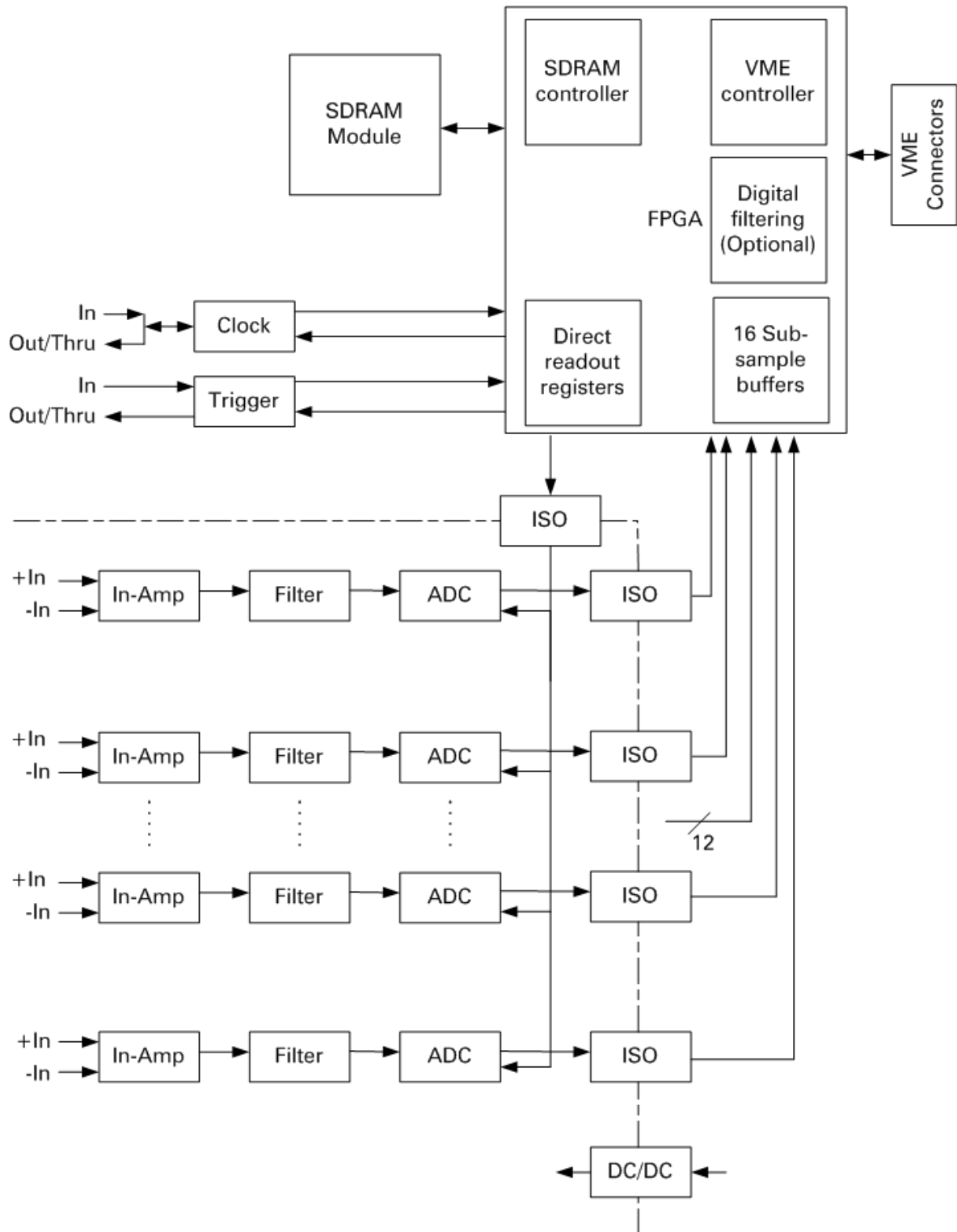

***Design and manufacturing of computer systems for industry, science and OEM***